

# ExactLogic BACnet Communicating Thermostat

## EXL01641 Sequence Datasheet

### Staged Unit Heaters/Cabinet Unit Heaters

Stage 1 Digital, Stage 2 Analog



BACnet is a registered trademark of ASHRAE. ASHRAE does not endorse, approve or test products for compliance with ASHRAE standards. Compliance of listed products to requirements of ASHRAE Standard 135 is the responsibility of the BACnet International. BTL is a registered trademark of the BACnet International.

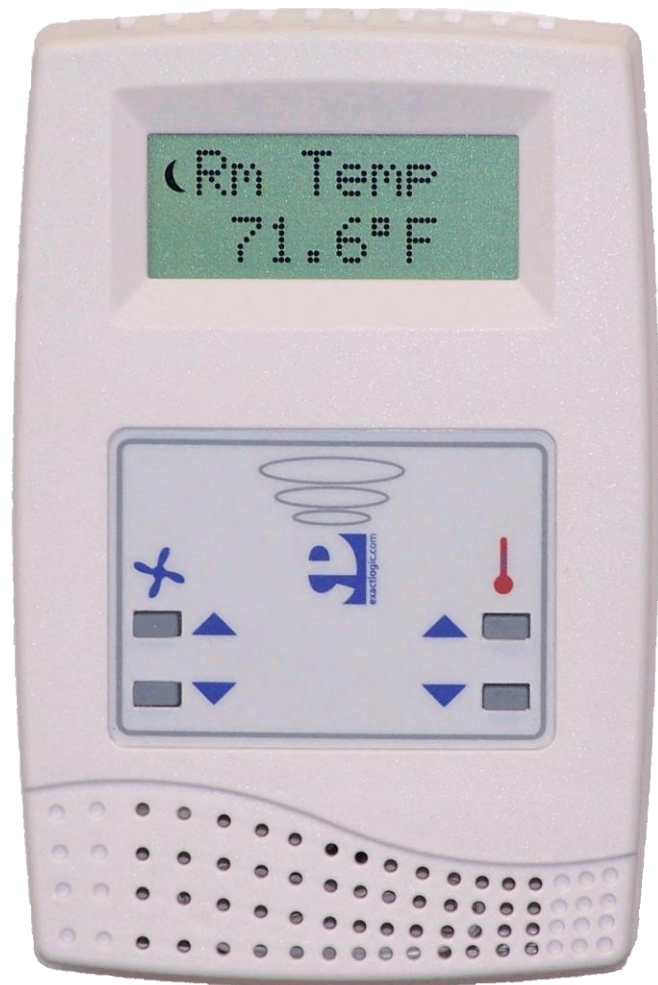

DataSheet Rev 1.12.011/Rev 4.0  
March 20, 2014

## Operating Sequence

### Standard Occupied

During normal occupied operation the display will show the current room temperature. The first press of either right pair of keys will show the current room setpoint. Additional presses will adjust the setpoint up or down by 0.5 degrees. The thermostat keypad will time out after 5 seconds without a key press, and the display will switch back to displaying the room temperature.

The left pair of keys allows for the adjustment of the fan speed. The current mode is shown with the first key press; additional key presses will show the adjustment to the mode. AV-62 is used to select the number of fan speeds, and AV-63 will show what speed the fan is currently set to. The table below will illustrate what values of AV-62 and AV-63 correspond to the fan speed a desired fan speed selection.

AV-62	Mode
0	AUTO-ON
1	OFF-AUTO-ON
2	1-2-AUTO
3	OFF-1-2-AUTO
4	1-2-3-AUTO
5	OFF-1-2-3-AUTO

AV-63	Fan Speed
0	OFF
1	Fan Speed 1
2	Fan Speed 2
3	Fan Speed 3
4	AUTO
5	ON

### Internal/External Thermistor Control

The thermostat control sequence can use the internal thermistor, an external thermistor connected to AI-2, or an external temperature transferred through the BACnet network to AV-10. Setting BV-67 to OFF (default) the thermostat will use the internal thermistor. Setting BV-67 to ON the control sequence will use the external thermistor. Setting BV-56 to OFF will select the external temperature on AI-2, setting BV-56 to ON will select the external network temperature transferred to AV-10. When setting BV-55 to ON, the lowest temperature between the internal thermistor and the temperature selected by BV-55 will be used for control. When BV-55 is set OFF, the temperature selected by BV-67 will be used for control.

The current controlling temperature is located at AV-20. This value will be displayed on the LCD of the thermostat and should be used on any workstation displays.

### Control Sequence – Staged Heat

The occupancy of the thermostat is controlled by BO-5. When active the thermostat will attempt to maintain its occupied setpoint. The deadband is controlled by the heating offset (default 1 degree). Should the room temperature get 1 degree below the current heating setpoint, the digital heat will turn on. The heating is staged based off a PI heating control signal, AV-8. Stage 1 and 2 heating commands are controlled by a heating signal setpoint at AV-38 and 39. The stage 1 heating command is digital at BO-2. The stage 2 heating command is analog at AO-0 or 1. The signal on AO-0 modulates from 0-10V, and AO-1 modulates from 10-0V. The output max and min voltages for AO-0 and 1 can be set at AV-40 through AV-43.

All outputs can be disabled by setting BV-66 ON.

Note: Digital heat outputs have a 180 second ON/OFF anti-short cycle.

---

## Fan Control

This thermostat has only one fan speed. This leaves mode 0 and 1 (AV-62) the only applicable fan speeds for this application. When the fan speed is in AUTO, the thermostat will turn on the fan when stage 1 heat is requested. The status point is BV-25. The fan will also start with a Fan Operating Mode set to Continuous, via BV-69.

All outputs can be disabled by setting BV-66 ON.

## ***Standard Unoccupied***

During unoccupied operation the thermostat will continue to display the room temperature. When in an unoccupied state pressing one of the right pair of keys will display a message indicating the thermostat is in night mode, preventing the setpoint from being adjusted. To adjust the room setpoint when unoccupied the thermostat must be set to night override.

## Control Sequence

When the occupancy is in the unoccupied condition, the room will be controlled by the unoccupied heating setpoint. The fan and heating stage will operate the same as the occupied control sequence.

## ***Night Override***

Set the night override by pressing one of the left pair of keys. The display will switch to allow the user to set the night override time. Additional presses of the keys will adjust the time up or down by 0.5 hour increments. The night override can be increase by the keypad up to the override limit set at AV-73, the default is 5 hours. When the thermostat is in night override, the first press of one of the left pair of keys will display the override time remaining. Additional key presses will add/subtract 0.5 hours to the time that was remaining. When the timer reaches zero the thermostat will reenter unoccupied mode.

Once the thermostat has entered the night override mode, the right pair of keys can be used to adjust the room setpoint. The thermostat keypad will time out after 5 seconds without a key press, and the display will switch back to displaying the room temperature.

The thermostat can be set into a night override by writing a value to AV-74 from a Workstation. The value can not exceed the night override limit set at AV-73. If the night override time is set higher than the limit, the night override timer will be set the limit. The night override limit default is 5 hours.

If the thermostat is command occupied while in night override, the override timer will be cleared to zero and the thermostat will enter a normal occupied mode.

## Control Sequence

When the thermostat is in the override mode, the room will be controlled by the occupied heating setpoint. The fan and heating stage will operate the same as the occupied control sequence.

Note: There is no fan control in the override mode. The fan will run in the AUTO mode.

## ***Motion/Humidity Option Card***

The Motion/Humidity Option Card is enabled by setting BV-64 to ACTIVE. This will automatically provide the required voltage to power the sensors. The motion sensor status will show on BI-1. Once the motion sensor does not sense

---

motion, the delay at AV-81 is used to delay the ACTIVE to INACTIVE command to the Scheduled Occupied command at BO-5, priority array entry 10. The Humidity value is shown on AI-1.

### ***Disabling of the Splash, Setup Menu, or Field Service Mode***

When the thermostat is installed in a public location there may be times when the setup of the thermostat will need to be disabled to prevent tenants from changing the configuration while still giving them access to change the setpoints and control after hours modes. The following points have been added to allow this:

BV-57 = Setting ACTIVE will disable the “EXACTLOGIC” splash display after key presses

BV-58 = Setting ACTIVE will disable access to the Setup Menu where the Network/MAC/Baud Rate/etc are set

BV-59 = Setting ACTIVE will disable access to the Field Service Mode where Time/Schedule/Setpoints/etc are set

## Input/Output Setup

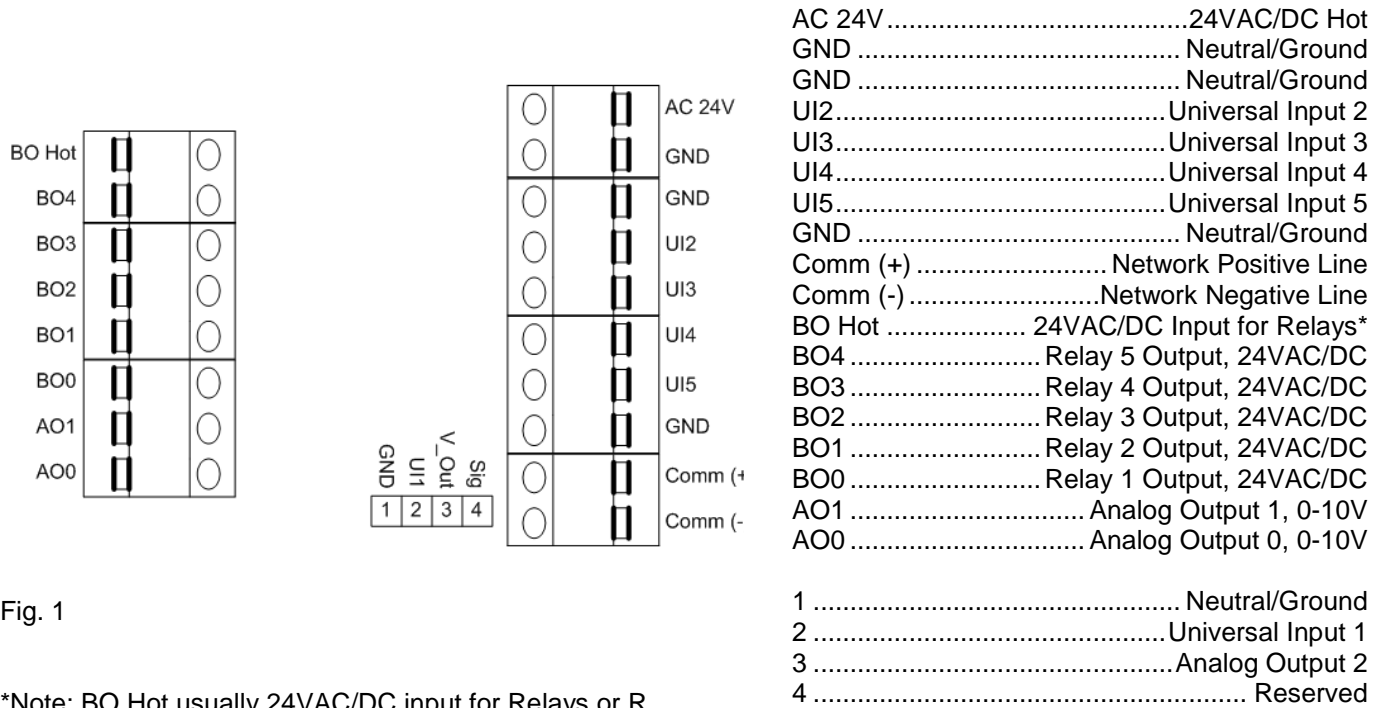

Fig. 1

\*Note: BO Hot usually 24VAC/DC input for Relays or R

## Output Wiring

Output	Function
BO0	Fan
BO1	
BO2	Stage 1 Heating
BO3	
BO4	
AO0	Stage 2 Heating 0-10 Vdc 0-100%
AO1	Stage 2 Heating 10-0 Vdc 0-100%

## Reserved BACnet Points

The following are points reserved by the thermostat for operation.

### Analog Inputs

Instance	Object Name	Description	Read/Write	Default
AI-0	Internal Thermister	Reading of the internal thermister in counts. 0-1024	R	variable
AI-1	Humidity	Reading of the internal humidity add on sensor	R	variable
AI-2	Ext. Room Temp	Optional external room temperature input	R	variable
AI-3	Analog Input 3	Reading of the external input 3 in counts. 0-1024	R	variable
AI-4	Analog Input 3	Reading of the external input 4 in counts. 0-1024	R	variable
AI-5	Analog Input 05	Reading of the external input 5 in counts. 0-1024	R	variable

### Analog Outputs

Instance	Object Name	Description	Read/Write	Default
AO-0	Stage 2 Heat 0-10V (0- 100%)	Stage 2 0-10V output for control of heating	R/W	0.0
AO-1	Stage 2 Heat 10-0V (0-100%)	Stage 2 10-0V output for control of heating	R/W	10.0
AO-2	Analog Output 2	Variable 0-14VDC, 150mA output	R/W	0.0

### Analog Values

Instance	Object Name	Description	Read/Write	Default
AV-0	Mode of Operation	The mode that the thermostat is currently in. 0 = Heat Mode 1 = Cool Mode 2 = Idle 3 = Afterhours 4 = Unoccupied Idle 5 = Unoccupied Heat Mode 6 = Unoccupied Cool Mode	R	4
AV-1	Analog Value 001			
AV-2	Analog Value 002			
AV-3	Analog Value 003			
AV-4	Current Htg SP	The setpoint that controls heating. If the room temperature goes below this setpoint the thermostat will enter heating mode.	R	80.0°F
AV-5	Reserved	This point is reserved for internal thermostat use and its value cannot be changed		
AV-6	Heating SP	The setpoint used for heating during occupied time. This setpoint is calculated by AV-66 (Current SP) – AV-70 (Heating Offset)	R	72.0°F
AV-7	Reserved	This point is reserved for internal thermostat use and its value cannot be changed	R	0



AV-8	Heat Signal	Current heating signal as a percent	R	0%
AV-9	Reserved	This point is reserved for internal thermostat use and its value cannot be changed	R	0
AV-10	Network Temperature	Temperature from an external sensor is transferred through the BACnet network to this point. Set BV-56 to use for sequence control.	R/W	0°F
AV-11	Analog Value 011			
AV-12	Analog Value 012			
AV-13	Analog Value 013			
AV-14	Analog Value 014			
AV-15	Analog Value 015			
AV-16	Analog Value 016			
AV-17	Analog Value 017			
AV-18	Analog Value 018			
AV-19	Reserved	This point is reserved for internal thermostat use and its value cannot be changed	R	varies
AV-20	Room Temp	Selected from either AI-2 or AI-0. BV-67 is used for selection. This is the value displayed on the LCD of the thermostat and should be used to display the temperature on any workstation display.		
AV-21	Analog Value 021			
AV-22	Analog Value 022			
AV-23	Analog Value 023			
AV-24	Analog Value 024			
AV-25	Analog Value 025			
AV-26	Analog Value 026			
AV-27	Analog Value 027			
AV-28	Analog Value 028			
AV-29	Analog Value 029			
AV-30	AI-0 Setup	Parameter used to set the input type. 0 = counts 1 = temperature 2 = 4-20mA 3 = 0-5V 4 = 0-10V 5 = pulse	R	1
AV-31	AI-1 Setup	See AV-30	R	0
AV-32	AI-2 Setup	See AV-30	R	0
AV-33	AI-3 Setup	See AV-30	R	0
AV-34	AI-4 Setup	See AV-30	R	0
AV-35	AI-5 Setup	See AV-30	R	0
AV-36	Analog Value 036			
AV-37	Analog Value 037			
AV-38	Stage 1 Setpoint	Percentage of the Heat Signal to engage Stage 1 Heating	R/W	5%
AV-39	Stage 2 Setpoint	Percentage of the Heat Signal to engage Stage 1 Heating	R/W	50%
AV-40	AO-0 Max Voltage	Maximum voltage outputted on AO-0	R/W	100%
AV-41	AO-0 Min Voltage	Minimum voltage outputted on AO-0	R/W	0%
AV-42	AO-1 Max Voltage	Maximum voltage outputted on AO-1	R/W	100%
AV-43	AO-1 Min Voltage	Minimum voltage outputted on AO-1	R/W	0%

AV-44	Analog Value 044			
AV-45	Analog Value 045			
AV-46	Analog Value 046			
AV-47	Analog Value 047			
AV-48	Analog Value 048			
AV-49	Analog Value 049			
AV-50	Heating Kp	Proportional Constant for the heating PI calculation	R/W	12
AV-51	Heating Ki	Integral Constant for the heating PI calculation	R/W	1
AV-52	Analog Value 052			
AV-53	Analog Value 053			
AV-54	Analog Value 054			
AV-55	Analog Value 055			
AV-56	Analog Value 056			
AV -57	Analog Value 057			
AV-58	Reserved	This point is reserved for internal thermostat use and its value cannot be changed	R	1.6
AV-59	Pseudo Ave Time Base	Factor used to average the room temperature. A small number will allow the room temperature to change faster over time. A large number will cause the room temperature to change slower over time.	R	100
AV-60	Cal Offset	The calibration offset for the internal thermistor.	R	variable
AV-61	Space Alarm Offset	This offset +/- the Current Cooling/Heating SP is used to determine if the space is too warm/cold, and set an alarm if necessary.	R/W	5.0°F/2.5°C
AV-62	# of Fan Speeds	Select the number of fan speeds for a multispeed fan. 0 = AUTO - ON 1 = Off - AUTO - ON 2 = 1-2-AUTO 3 = Off-1-2-AUTO 4 = 1-2-3-AUTO 5 = Off-1-2-3-AUTO	R/W	4
AV-63	Current Fan Speed	The fan speed the thermostat is currently running. 0 = OFF 1 = Fan Speed 1 2 = Fan Speed 2 3 = Fan Speed 3 4 = AUTO 5 = ON	R	4
AV-64	Vacant Clg SP	Used in Hotel Mode. When a room is known vacant, the setpoint can be set below the unoccupied setpoint.	R/W	85.0°F
AV-65	Vacant Htg SP	Used in Hotel Mode. When a room is known vacant, the setpoint can be set below the unoccupied setpoint.	R/W	55.0°F
AV-66	Room Setpoint	The occupied room setpoint	R/W	73.0°F/23.0°C
AV-67	Occupied Sp Hi Limit	The maximum occupied room setpoint allowed.	R/W	85.0°F/30.0°C
AV-68	Occupied Sp Lo Limit	The minimum occupied room setpoint allowed	R/W	55.0°F/13.0°C



AV-69	Clg Offset	The offset from Room Setpoint used to calculate the Occupied Cooling SP	R/W	1.0°F/0.5°C
AV-70	Htg Offset	The offset from Room Setpoint used to calculate the Occupied Heating SP	R/W	1.0°F/0.5°C
AV-71	Unoccupied Clg Sp	The cooling setpoint used when the thermostat is unoccupied.	R/W	80.0°F/27.0°C
AV-72	Unoccupied Htg SP	The heating setpoint used when the thermostat is unoccupied.	R/W	60.0°F/16.0°C
AV-73	After Hours Limit	The maximum hours the thermostat is allowed to run during afterhours time. Setting this will set the thermostat to occupied operation. (0-99.9 hrs)	R/W	5.0 hrs
AV-74	After Hours Timer	The current amount of afterhours time left.	R	0.0 hrs
AV-75	Reserved	This point is reserved for internal thermostat use and its value cannot be changed	R	
AV-76	Reserved	This point is reserved for internal thermostat use and its value cannot be changed	R	
AV-77	Reserved	This point is reserved for internal thermostat use and its value cannot be changed	R	
AV-78	Reserved	This point is reserved for internal thermostat use and its value cannot be changed	R	
AV-79	Reserved	This point is reserved for internal thermostat use and its value cannot be changed	R	
AV-80	Reserved	This point is reserved for internal thermostat use and its value cannot be changed	R	
AV-81	Motion OFF Delay	The amount of time to delay the ON->OFF transition of the motion sensor occupied command after no motion is detected	R/W	900 sec
AV-82	Analog Value 082			
AV-83	Analog Value 083			
AV-84	Analog Value 084			
AV-100	Analog Value 100	Internal thermister display descriptor. The present value is automatically transferred. The AV description holds the descriptor to display.	R	variable
AV-101	Analog Value 101	Display descriptor. Transfer the value to display to the present value. The AV description holds the descriptor to display.	R/W	
AV-102	Analog Value 102	Display descriptor. Transfer the value to display to the present value. The AV description holds the descriptor to display	R/W	
AV-103	Analog Value 103	Display descriptor. Transfer the value to display to the present value. The AV description holds the descriptor to display	R/W	
AV-104	Analog Value 104	Display descriptor. Transfer the value to display to the present value. The AV description holds the descriptor to display	R/W	
AV-105	Analog Value 105	Display descriptor. Transfer the value to display to the present value. The AV description holds the descriptor to display	R/W	
AV-106	Analog Value 106	Display descriptor. Transfer the value to display to the present value. The AV description holds the descriptor to display	R/W	

AV-107	Analog Value 107	Display descriptor. Transfer the value to display to the present value. The AV description holds the descriptor to display	R/W	
AV-108	Analog Value 108	Display descriptor. Transfer the value to display to the present value. The AV description holds the descriptor to display	R/W	
AV-109	Analog Value 109	Display descriptor. Transfer the value to display to the present value. The AV description holds the descriptor to display	R/W	
AV-110	Analog Value 110	Display descriptor. Transfer the value to display to the present value. The AV description holds the descriptor to display	R/W	
AV-111	Analog Value 111	Display descriptor. Transfer the value to display to the present value. The AV description holds the descriptor to display	R/W	
AV-112	Analog Value 112	Display descriptor. Transfer the value to display to the present value. The AV description holds the descriptor to display	R/W	

## Binary Inputs

Instance	Object Name	Description	Read/Write	Default
BI-0	Binary Input 00		R	
BI-1	Motion	Status of the motion add-on sensor	R	
BI-2	Binary Input 02		R	
BI-3	Binary Input 03		R	
BI-4	Binary Input 04		R	
BI-5	Occupied Relay	Optional occupied relay	R	

## Binary Outputs

Instance	Object Name	Description	Read/Write	Default
BO-0	Fan	Output for Fan Control	R/W	OFF
BO-1	Binary Output 01			
BO-2	Stage 1 Heat	Stage 1 heating command	R/W	OFF
BO-3	Binary Output 03			
BO-4	Binary Output 04			
BO-5	Scheduled Occupied	Logical point only. Used for scheduling purposes. INACTIVE is unoccupied.	R/W	OFF

## Binary Values

Instance	Object Name	Description	Read/Write	Default
BV-0	Bad Sensor Alarm	Alarm for a bad internal thermister	R	OFF
BV-1	Binary Value 001			
BV-2	Binary Value 002			
BV-3	Binary Value 003			
BV-4	Binary Value 004			
BV-5	Binary Value 005			
BV-6	Binary Value 006			
BV-7	Binary Value 007			
BV-8	Binary Value 008			
BV-9	Binary Value 009			
BV-10	Program Status	Used to determine if the sequence was loaded correctly on a BACnet Restore or power up.	R	OFF
BV-11	Binary Value 011			
BV-12	Binary Value 012			
BV-13	Binary Value 013			
BV-14	Binary Value 014			
BV-15	Binary Value 015			
BV-16	Binary Value 016			
BV-17	Binary Value 017			
BV-18	Binary Value 018			
BV-19	Binary Value 019			
BV-20	Binary Value 020			
BV-21	Binary Value 021			
BV-22	Binary Value 022			
BV-23	Binary Value 023			
BV-24	Binary Value 024			
BV-25	Stage 1 Request	Stage 1 heating is requested	R	OFF
BV-26	Stage 2 Request	Stage 2 heating is requested	R	OFF
BV-27	Binary Value 027			
BV-28	Binary Value 028			
BV-29	Binary Value 029			
BV-30	Binary Value 030			
BV-31	Binary Value 031			
BV-32	Binary Value 032			
BV-33	Binary Value 033			
BV-34	Binary Value 034			
BV-35	Binary Value 035			
BV-36	Binary Value 036			
BV-37	Binary Value 037			
BV-38	Binary Value 038			
BV-39	Binary Value 039			
BV-40	Occupied Status	The status of this point switches the thermostats occupancy settings. ON when the thermostat is in Occupied Setpoint Mode or After Hours Mode.	R	OFF
BV-41	Opt. Start Warmup	A Warmup command has been sent to the thermostat. When ON the thermostat will switch to occupied settings.	R/W	OFF

BV-42	Opt. Start Cooldown	A Cooldown command has been sent to the thermostat. When ON the thermostat will switch to occupied settings.	R/W	OFF
BV-43	Occ Set point Mode	The thermostat has been commanded occupied via BO-5, or a Warmup/Cooldown command has been sent via BV-41/BV-42.	R	OFF
BV-44	After Hours Status	The thermostat has been set to afterhours mode. When ON the thermostat will switch to occupied settings.	R	OFF
BV-45	Reserved	This point is reserved for internal thermostat use and its value cannot be changed	R	OFF
BV-46	Binary Value 046			
BV-47	Binary Value 047			
BV-48	Binary Value 048			
BV-49	Update Descriptors	When ON any descriptor change will be sent the thermostats LCD, this point will auto reset to OFF.	R/W	OFF
BV-50				
BV-51	BI-5 for Occupancy	ON = BI will be used to indicate zone occupancy OFF = BI is not used for occupancy	R/W	OFF
BV-52	Binary Value 052			
BV-53	Binary Value 053			
BV-54	Binary Value 054			
BV-55	Temperature Control Mode	When ACTIVE, the external sensor selected by BV-56 will be used for control. When INACTIVE, the sensor selected by BV-67 will be used for control.	R/W	OFF
BV-56	Ext Temp Local/Remote	When ACTIVE, the external sensor for control is from the network. When INACTIVE, the external sensor for control is on AI-2.	R/W	OFF
BV-57	Disable Splash	When ACTIVE, the "EXACTLOGIC" splash will not show after key presses	R/W	OFF
BV-58	Disable Setup Menu	When ACTIVE, there will be no access to the Setup Menu where the Network/MAC/Baud Rate is set	R/W	OFF
BV-59	Disable FSM Menu	When ACTIVE, there will be not access to the Field Service Mode where the Time/Schedule/Point Access is set	R/W	OFF
BV-60	Binary Value 060			
BV-61	Binary Value 061			
BV-62	Binary Value 062			
BV-63	Binary Value 063			
BV-64	Motion/Humidity Enbl	When ACTIVE, the power to the Motion/Humidity add-on card is set to the proper voltage	R/W	OFF
BV-65	Binary Value 065			
BV-66	Disable Unit	When ON this point will disable and lockout all analog and binary outputs.	R/W	OFF
BV-67	Room Temp Select	When OFF, the internal thermistor is selected for the control sequence. When ON, an external thermistor attached to AI-1 is selected for control of the sequence		
BV-68	Backlight Off/On	When ON the LCD backlight will remain on	R/W	OFF

BV-69	Fan Op Mode	Controls if the fan will cycle or run continuously. OFF = Cycle, ON = Continuous, BV-40 must also be ON.	R/W	OFF
BV-70	Room Vacant Status	When ON the thermostat will run on Vacant Heating/Cooling setpoints, AV-64/AV-65.	R/W	OFF
BV-71	C/F	Sets the thermostat to display temperatures in Celsius or Fahrenheit. This point is set through the setup menu. ON = F, OFF = C	R	ON
BV-72	Binary Value 072			
BV-73	Binary Value 073			
BV-74	Hotel Mode	This point is reserved for internal zone damper use and its value cannot be changed	R	OFF
BV-100	Binary Value 100	Enable internal thermistor descriptor	R/W	ON
BV-101	Binary Value 101	Enable descriptor	R/W	OFF
BV-102	Binary Value 102	Enable descriptor	R/W	OFF
BV-103	Binary Value 103	Enable descriptor	R/W	OFF
BV-104	Binary Value 104	Enable descriptor	R/W	OFF
BV-105	Binary Value 105	Enable descriptor	R/W	OFF
BV-106	Binary Value 106	Enable descriptor	R/W	OFF
BV-107	Binary Value 107	Enable descriptor	R/W	OFF
BV-108	Binary Value 108	Enable descriptor	R/W	OFF
BV-109	Binary Value 109	Enable descriptor	R/W	OFF
BV-110	Binary Value 110	Enable descriptor	R/W	OFF
BV-111	Binary Value 111	Enable descriptor	R/W	OFF
BV-112	Binary Value 112	Enable outside air descriptor	R/W	OFF